



SCHEDA TECNICA PRODOTTO

DATASHEET

ARTICOLO: LED Tigre 220W

CODICE: 28701/LED/25

Caratteristiche meccaniche/Mechanical features:

Corpo/Body:	Alluminio pressofuso/Die-cast aluminium
Cornice/Frame:	Alluminio pressofuso/Die-cast aluminium
Colore/Colour:	Grigio RAL 9007/Grey RAL 9007
Riflettore/Reflector:	PC metallizzato/Metalised PC
Schermo/Shield:	Vetro temperato/Tempered glass
Staffa di fissaggio/Mounting bracket:	Lamiera di acciaio/Steel sheet
Viteria/Screws:	INOX AISI 304
Dissipazione/Dissipation:	Statica/Static
Peso/Weight:	7,5kg

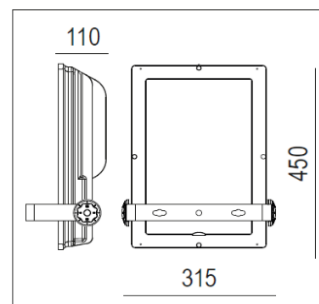

IP66

IK09

850°



Caratteristiche elettriche/Electrical features:

Alimentazione/Power supply:	220-240V AC 50/60Hz
Potenza/Power:	220W
Fattore di potenza/Power factor:	>0,95
Corrente di spunto/Inrush current:	50A-200µS
Efficienza/Efficiency:	0,92
Filtro antidisturbi/Noise filter:	EN 55015
Alimentatore/Driver:	Incluso/Included
Aspettativa di vita/Life expectation:	100.000h (L90B10)
Indice Mac Adam/Mac Adam index:	3
Rischio fotobiologico/Photobiological risk:	RG0



Caratteristiche illuminotecniche/Photometric features:

Tipo di LED/LED type:	LED COB
Flusso luminoso/Luminous flux:	26400 lm
Lm/W:	120 lm/W
CCT:	4.000K
CRI:	>80
Ottica secondaria/Secondary optic:	25°
Accessori/Accessories:	cod. 703952.NEW - Codolo per testa palo/Pole head spigot cod. RO0640/N - Limitatore di sovratensione/Surge protector cod. 11111 - Staffa per applicazione di due apparecchi/Bracket for the application of two lighting fixtures

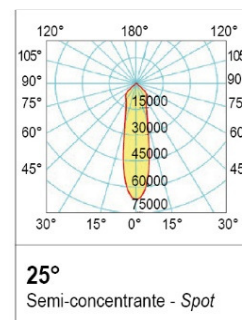

Conforme alle seguenti norme/Complying with the following standards:

Sicurezza/Safety:	Generale/General:	EN-60598-1
	Particolari/Particular:	EN-60598-2-1
	Moduli LED/LED Modules:	EN-62031+A1
Sicurezza fotobiologica/Photobiological safety:		EN 62471 (Risk exempt)
Esposizione umana ai campi elettromagnetici/Human exposure to electromagnetic fields:		EN-62493
Immunità EMC/EMC immunity:		EN-61547
Compatibilità elettromagnetica/Electromagnetic compatibility:		EN-61000-3-3
Limiti di emissioni armoniche/Limits of harmonic emissions:		EN-61000-3-2

